



# Extending the Scope of Herschel Spectral Tools with Interface-Oriented Design

Martin Melchior <sup>1)</sup>, Peter Davis-Imhof <sup>2)</sup>, André Csillaghy <sup>1)</sup>

1) University of Applied Sciences North-Western Switzerland,  
 2) Blue Sky Spectroscopy, Lethbridge (Alberta), Canada

**Herschel spectral tools are designed to process hyper-spectral data structures. Java interfaces define rules for accessing and using the data and make the tools work across the different instruments.**

**Spectral Tools for Data Reduction and Analysis**

Tools allow processing **hyper-spectral data structures**, as obtained by any **imaging spectroscopy** techniques, in an **instrument-specific way**.

*Example of use:* within the **Herschel Interactive Processing Environment (HIPE)** by calibration scientists or by end-user astronomers, during the pipeline processing or in the subsequent data analysis.

*Example operations:* arithmetic operations, statistics (e.g. average), extract, resample, smooth, fit, view, ...

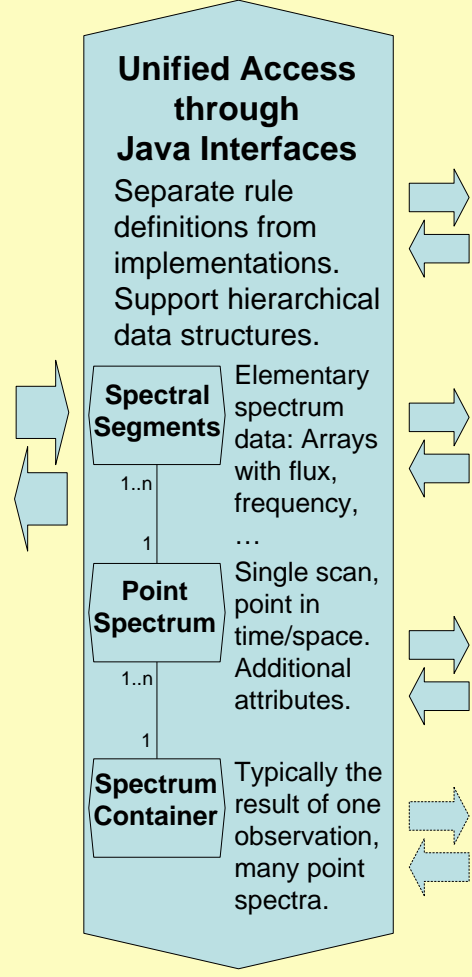

**Instrument-Specific Data Structures**

- Underlying datatypes defined in the Herschel Software System: Tabular datasets.
- Different ways how these common datatypes are used.
- Instrument-specific meta data such as house-keeping data.

**External Formats**

What formats to support: FITS, VOTable, ...?

**Interoperability with Other Tools**

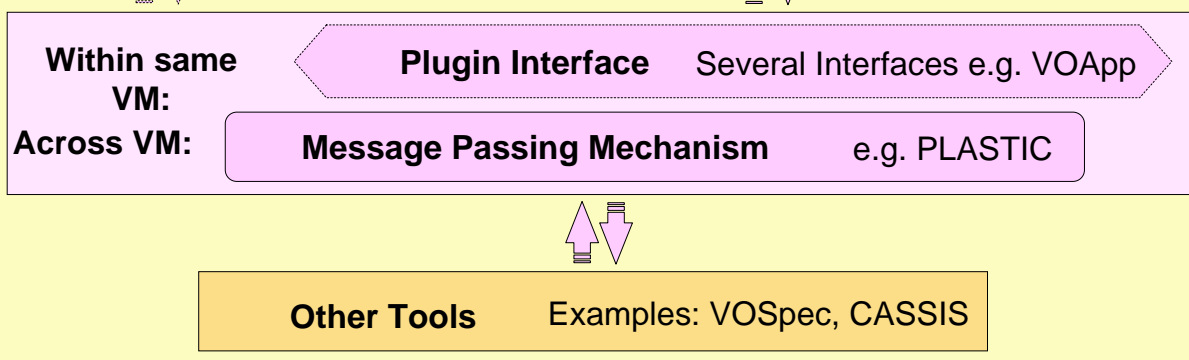

## Instrument-specific behavior of the spectral tools

The tools can be configured using xml-specifications to react to instrument-specific data and meta data contained in the data structures in an instrument-specific way. An open issue is how to provide specifications through the interoperability layer.